

Specifications

Output Power HP (kW)	7.5 (5.5)
Phase	3 Phase
Pole	2 Pole
Frame Number	132S

Degrees of Protection	IP 22
Enclosure Construction	Drip-proof
Thermal Class	Class B (130°C)

Alignment	Vertical
Frame Material	Steel plate

Power Transmission	Direct-couple or Belt Driven
Direction of Rotation	Counterclockwise (CCW) viewed from shaft-end side



Connection Type	Terminal Block (6 Leads)
Coating Colour	Munsell N5.5 (Gray)
Conformed Standard	IEC 60034-1 & JEC-2137-2000



Voltage & Frequency	HT Type
	380~415V 50Hz 380~440V 60Hz (suitable for Y-Δ starting)

* () is dimension without drip-proof cover

Dimensions (mm)

Flange Number	Motor								
	D	IE	LA	LB	LC	LE	LG	LL*	LZ
FF265	220	156.5	265	230 j6	300	4	20	393 (369)	14.5

Terminal Box			Shaft End						
KB	KD	KL	LR	Q	QK	S	T	U	W
292	27	181	80	80	63	38 k6	8	5	10

Bearing No.		Approximated Weight (kg)	Approximated Packing Dimensions (LxWxH)	Gross Weight (kg)
Drive End	Opposite			
6308ZZ	6207ZZ	52	569 x 427 x 384	59

Connection & Connection Diagram

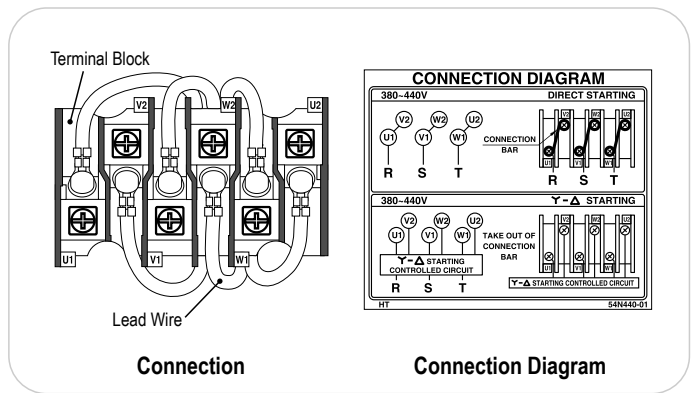

Circumstance Conditions

Ambient Temperature	-20 ~ +40°C
Ambient Humidity	85% RH or less
Operating Altitude	Less than 1,000m above sea level
Environment	No bursting / erosive gas or vapor

Motor Characteristics

Type	Hz	V	50% Load			75% Load			100% Load				Torque(%)		Is (A)	Inertia GD ² (kg-m ²)	
			(A)	Eff(%)	PF(%)	(A)	Eff(%)	PF(%)	(A)	Eff(%)	PF(%)	Speed (r/min)	Torque (kg-m)	Ts			Tm
HT	50	380	6.65	0.85	0.74	8.69	0.88	0.82	11.0	0.88	0.86	2900	1.85	201	264	69.4	0.046
		415	7.70	0.83	0.60	9.32	0.86	0.72	11.3	0.87	0.78	2910	1.84	241	311	75.7	
	60	380	5.73	0.88	0.83	7.97	0.89	0.88	10.4	0.89	0.90	3480	1.54	163	231	74.5	
		440	5.90	0.85	0.72	7.59	0.88	0.81	9.51	0.89	0.85	3500	1.53	220	309	68.2	